



● **No Jam Debris Conveyor**

Features molded-in full-width cleats that move large debris without jamming. High-strength belt material provides long wear and maximum uptime. Controlled from in-cab, including reverse. Built-in washdown for quick, easy cleanup.

● **Wide Sweeping Path**

Hydraulically-driven main and side brooms create wide 10 ft. (3048 mm) sweeping path for maximum productivity.

● **Minimal Noise Levels**

Cab, chassis and sweeping system designed for low in-cab and drive-by noise levels, providing maximum operator comfort and safety.

● **Fully Air-Sprung Side Brooms**

Exclusive trailing arm design and four-way spring mounted movement (side-to-side, up-and-down) minimize broom damage while maximizing surface contact and efficiency. Large 42 in. (1067 mm) brooms provide maximum digging power.

● **Hydraulically Driven Main Broom**

The main broom, 60 inch (1524 mm) long x 35 inch (889 mm) in diameter is hydraulically driven and has in-cab variable broom speed for flexibility in varying sweeping conditions. Down pressure can be adjusted by the operator from the cab while moving.

● **Patented Air Bag Suspension**

Provides fully sprung rear axle for transport comfort, plus solid axle for superior sweeping and stable dumping operations.

● **Variable High Dump Hopper**

Unloads at any point from chassis level to 10 ft. (3048 mm). Hopper lifts on trouble-free, twin hydraulic cylinder, dual stage mechanism. Center position keeps weight between dual tires during dumping operations and maintains proper weight distribution as sweeper loads. Load is clearly visible through tempered safety glass window. Up to 11 inches (279 mm) of side shift allows greater truck mirror/container clearance and extends hopper reach into container.



● **High Capacity Tool Box**

Large, uniquely designed 15 cubic foot toolbox, provides space for long handled broom and shovels and bulky items like grease pails.

● **Dual Diesel Engine Design**

Power to the sweep system is provided by an efficient John Deere® 4 cylinder, turbocharged 49 HP @2800 RPM engine. The dedicated sweep system engine produces superior digging at required ground speed. Truck engine RPM or ground speed do not affect broom or conveyor speed.

● **Easy In-Cab Operation**

Center-mounted console provides access to all sweeper controls from either driving position. Includes hopper, conveyor, rear suspension, adjustable water and broom controls, plus full load indicator. Broom speed, conveyor speed and digging pressure are adjustable independently of truck RPM. Reverse gear automatically raises sweeping components to prevent damage.

● **Proven Cab-Over Chassis**

High visibility commercial-grade cab dualized with genuine OEM parts. Fully sprung chassis minimizes rough road conditions and maximizes operator comfort and control. Complies with FMVSS standards.

● **Corrosion-Resistant Water System**

Minimizes dust generation by spraying directly at the source. Large 280 gallon (1060 L) capacity maximizes sweeping time. System includes long-life run-dry pump, polyethylene tanks, brass fittings and nozzles, and anti-syphon fill.

● **Helpful Maintenance Features**

Four access doors (with locks) open wide for easy access to all sweep system components and auxiliary engine. Built-in steps and steel service platform provide stable work surfaces.

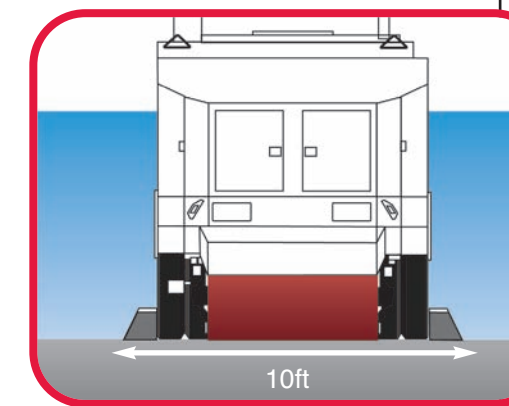

A Closer Look



Waterless Eagle

If you need a proven broom sweeper with high dump capability, superior operator comfort and safety at highway transport speed, the Elgin Eagle® is the solution. With its exclusive No Jam conveyor, wide sweep path and trouble-free

lift mechanism, the Eagle provides unequalled productivity in a variety of applications,

including municipal and contractor sweeping to

road construction and resurfacing work.

The Eagle is easy to operate, easy to maintain

and built to last. Customized with your choice

of options, the Eagle is sure to fit your sweep-

ing application. The Elgin Eagle has been designed and manufactured to the exacting

quality standards that have made Elgin a world

leader in sweeper manufacturing. And thanks

to a worldwide factory trained dealer network,

you can be sure of complete satisfaction on

delivery and far down the road.



Eagle® 4 Wheel Broom Sweeper

Options



Front Spray Bar

Cab controlled water spray bar helps settle debris under extremely dusty conditions. Constructed from corrosion-resistant copper pipe and brass nozzles (4).



In-Cab Side Broom Tilt

Allows operator to sweep effectively in variably-pitched gutters. On-the-go pitch adjustment with a simple variable rocker switch ensures proper broom angle.



LifeLiner® Hopper System

The LifeLiner® hopper system is a specially designed hopper liner and finish system that greatly improves the life, durability, and functionality of a sweeper hopper.

Additional Options

- Rotating beacon or strobe light
- Rotating beacon/strobe light guard
- Air conditioner
- Carbide dirt shoes
- Arrowboard
- Auto-Lube automatic lubrication system
- Auxiliary engine automatic shutdown
- Silicone hoses on auxiliary engine
- Extended side broom reach
- Main broom hour meter
- Side broom position indicators
- One-touch sweep resume system
- Alternative fuel
- Waterless dust control

Value-Added Services

- Elgin's commitment to the customer continues long after the sale.
- Factory-trained worldwide dealer network for assistance with service and maintenance
 - Genuine OEM Parts
 - Elgin Training Center with hands-on instruction for operators and service personnel
 - Customized leasing and financial services

Dimensions

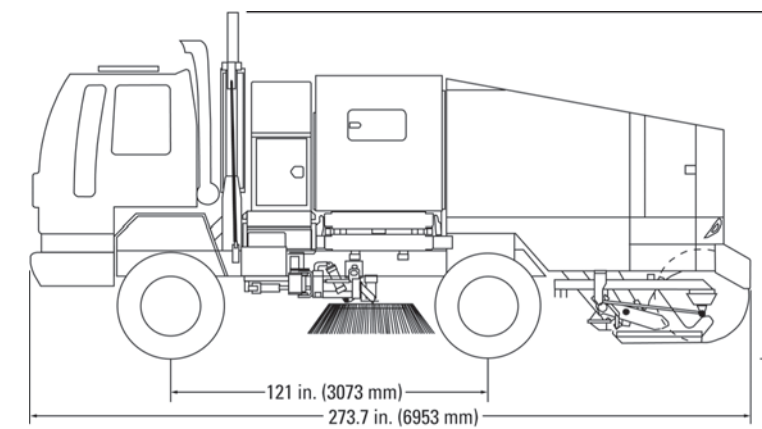

Warranty

Elgin Sweeper Company backs the Eagle sweeper with a one-year limited warranty. The Eagle is warranted against defects in material or workmanship for a period of 12 months from the date of delivery to the original purchaser. Optional extended warranty packages are available. Consult your Elgin dealer for complete warranty information.

Your Elgin Dealer is:



Elgin Sweeper Company
Subsidiary of Federal Signal Corporation
1300 W. Bartlett Road
Elgin, Illinois, U.S.A. 60120-7529
(847) 741-5370 Phone
(847) 742-3035 Fax
www.elginsweeper.com

ISO-9001 and PM-10 Advantages

The Eagle is manufactured in an ISO-9001 facility and offers an optional package to meet PM-10 requirements for compliance with SCAQMD Rule 1186. John Deere is a registered trade mark of Deere & Company.

Specifications subject to change without notice. Some items shown may be optional. Elgin® and Eagle® are registered trademarks of Elgin Sweeper Company. Effective 5/08 P/N 0705289D Printed in U.S.A. © 2008 Federal Signal Corporation Federal Signal Corporation is listed on the NYSE by the symbol FSS.

ELGIN®



EAGLE®