



VACTOR®
HXX
VACUUM EXCAVATORS

PROVEN PERFORMANCE

- *Excavating remotely at long distances*
- *Exposure of live gas distribution lines*
- *Utility and pipe location*
- *Utility excavation*
- *Excavation in frozen ground*
- *Directional drilling*
- *Pipe and line installation*
- *Potholing*
- *Slot Trenching*
- *Water-line repair*
- *Valve box clean out*
- *Sign and pole installation*





The Vactor HXX HydroExcavator is a powerful machine that can tackle major excavations while still providing safe, non-destruction digging in a wide range of applications. The HXX HydroExcavator comes from Vactor Manufacturing who for over 50 years has been supplying contractors and municipalities with durable, reliable products using air conveyance, high pressure water and vacuum technology.

The Vactor HydroExcavator was designed and engineered as a purpose built hydroexcavator with contractor input throughout the process. Tough and reliable, built to work in freezing conditions as well as in the extreme heat of summer.

The Vactor HXX can increase worksite safety and decrease the cost of digging by avoiding the tremendous expense associated with power outages, burst waterlines or gas explosions that can result when a backhoe, trencher or other mechanical earth mover hits a buried utility. It also allows the operator to perform precision excavating, a less-invasive method that causes less surface damage than traditional digging methods.

***With the Vactor HXX HydroExcavator you can count on
Safe – Smart - Reliable vacuum excavation.***

The Vactor HXX HydroExcavator, first introduced over a decade ago, uses high pressure water or the optional pressurized air to break up and loosen the soil, while a high-flow vacuum system lifts the soil up and out of the excavation area. This method of excavation allows operators to dig with precision, in a less invasive manor that causes less surface damage than traditional digging methods. Locating and exposing existing utility lines can be accomplished in a safer, more efficient manner avoiding costly and even deadly strikes.

Debris Body:

The 12 cubic yard debris body is fabricated from corrosion and abrasion resistant steel. A 50 degree dump angle facilitates fast removal of material. The body is ¼ inch thick Ex-Ten steel and rib reinforced to meet 30" Hg minimum. A hydraulically activated, flat style ¾ rear door, hinged at the top with replaceable neoprene seal and four rod and receiver locks ensure a tight close. Inside the tank are dual air ports with dual 10 inch stainless steel float ball shut off system.

Hydraulic system:

The hydraulic reservoir has a capacity of 50 gallons with strainers on all suction lines. There is an oil-level sight gauge, an inspection hatch for maintenance and a 10 micron spin-on type filter.

Water Tanks:

1200 Gallon SXP (Superlinear XL polyethylene) insulated water tank retains heated water temperature longer, reducing the likelihood of freezing during operation in harsh winter weather. The tank design has a faster water heat time than other tank styles, and was designed for water temperatures as high as 100 degrees F. It withstands ambient temperatures from -40 degrees F to 120 degrees F. The lighter weight tank reduces fuel consumption while increasing payload availability and hauling capacity. The SXP tank features a 3/8 inch thick outer shell and a 3/8 inch thick foam liner. The system comes with an anti-siphon device and anti-splash valve with 25 foot water fill hose and connectors and a water-level indicator with low level alarm.

Water System:

The multi-flow pump allows water pressure adjustment with the push of a button for digging in various conditions. The water system is rated at 10 gpm @2500 psi, the maximum pressure recommended for safe excavation. It is powered by a hydraulically operated triplex piston water pump. Each unit includes a standard handgun hose 3/8 inch x 75 ft. with operating pressure of 3500 psi and burst pressure of 14,500 psi. The handgun and water pump can be mounted in an optional heated cabinet for protection against cold weather conditions. Optional handguns and nozzles are available for various applications.

Operator's Station & Controls:

A user-friendly, ergonomically designed control box is located curbside for easy access and efficient operation. Enclosed in an aluminum box, it is protected from environmental elements. Controls include a tachometer and hour meter for both chassis and blower, temperature indicators for various systems, water system on/off with multi-flow, complete boom and body dump functions, E-Stop and more. A wireless remote is standard, putting all of the controls in the operator's hands directly at the worksite.



The operator can control the boom up/down, in/out and left/right with the wireless controls.



Vacuum System:

The HXX features a chassis powered positive displacement blower for a simple, single engine vacuum source. A Hibon 8702 Tri-Lobe Blower (28 inch HG) 5250 cfm @ maximum speed 2000 rpm is used. Ultra quiet inlet and outlet silencers are acoustically matched to the blower. A direct drive OMSI transfer case and a vacuum relief located at the inlet of the final filter allow the operator to vent to the atmosphere. To accommodate the increase in the air-routing performance, enhanced centrifugal cyclones are designed to improve air filtration, minimizing material pass through of the blower causing premature wear and expensive repairs.*

Boom & Vacuum Hose:

The 7 ft hydraulic extendable boom, top mounted, 320° rotating boom with telescopic option maximizes the work area. The 8 in inside diameter hose allows easy passage of large, thick material. Work area is large with a 22 ft reach from the centerline of the truck. Various aluminum flanged pipes are available for added reach.

Electrical:

The entire electrical system is moisture and vapor sealed, and protected by circuit breakers. The electrical connections require no exposed wires or terminals and the light bulbs are shock mounted.



The Choice Is Yours.

The Vactor HydroExcavator's modular design allows you to select options that meet your specific needs so you can achieve the maximum productivity you expect.

Options

- Air compressor for excavation or air tool use
- 400,000 BTU/hr or 940,000 BTU/hr water heater helps cut through frozen ground and clay
- Cold Weather Package includes a heated pump and hose reel cabinet to protect against winter weather



- 20 gpm water pump
- Hydraulic tool package
- Second operator's station
- Additional tool boxes

- Stainless steel water tanks
- 15 cubic yard volumetric capacity debris body
- 7 foot hydraulic telescopic boom with 320 degree rotation



Safe, Smart, Reliable

*Note: A PD vacuum system with Roots 824 blower or a centrifugal fan are also available as vacuum source options

Specifications and Options

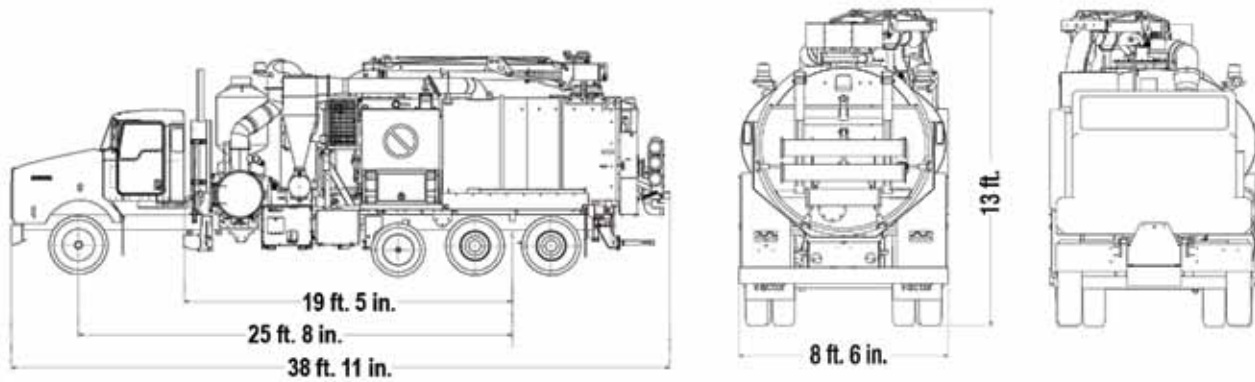

Debris Body

12 cu yd volumetric debris body
1/4 inch round design, abrasion and corrosion resistant Ex-Ten steel
Flat style, 3/4 rear door, hinged at top with replaceable neoprene seal
Hydraulic rear door open, close, locking
Front mounted hydraulic dump cylinder, 50 degree dump angle, power up / power down

Water Tanks

1200 gallon capacity
SXP (Superlinear XL polyethylene) insulated
Double wall design consisting of a 3/8 inch thick outer shell, 3/8 inch thick foam liner
Anti-siphon device and anti-splash valve
25 foot water fill hose and connectors
Water-level indicator with low level alarm
5-yr warranty against corrosion and cracking

Water System

Rated at 10 gpm @ 2500 psi
Hydraulically operated triplex piston water pump
Handgun hose 3/8 inch x 75 ft operating pressure of 3500 psi burst pressure of 14,500 psi

PD Vacuum System (Hibon 8702)

Hibon 8702 Tri-Lobe (28 inch Hg) 5250 cfm @ max. speed 2000 rpm
Ultra-quiet inlet and outlet silencers acoustically matched to blower
Direct drive OMSI transfer case
Vacuum relief located at the inlet of final filter to allow operator to vent to atmosphere

PD Vacuum System (Roots 824)

Roots 824 rotary lobe (18 inch Hg) 3500 CFM @ max speed 2250 rpm
Three vacuum reliefs incorporated and set at 18" Hg for added protection of vacuum system
Includes a micron final filter screen and housing, located prior to the blower inlet
Chassis driven directly through continuous-duty transfer case
Lighter weight enhances fuel economy and payload

FAN Vacuum System

Dual 38 inch aluminum two-stage centrifugal compressor / fan system
Hydrostatic fan drive system
Vacuum relief located at the inlet of debris tank to allow operator to vent to atmosphere

Boom & Vacuum Hose

7 ft hydraulic extendable boom, top mounted, with 320 degrees of rotation
22 ft reach from the centerline of truck

Hydraulic System

PD: Hydraulic reservoir capacity of 50 gal with strainers on all suction lines
FAN: Hydraulic reservoir capacity of 65 gal with strainers on all suction lines
Oil-level sight gauge/10 micron spin-on type filter

Electrical

Entire system will be moisture and vapor sealed and protected by circuit breakers
Electrical connections require no exposed wires or terminals
Light bulbs will be shock mounted

Paint

Prior to painting, all metal surfaces will be shot blasted and phosphate washed
Module components will be painted prior to assembly

Options

15 cu yd volumetric capacity debris body
Cold-weather package
Air purge system utilizing chassis air system
Water heater - 400,000 BTU / hr
Water heater - 940,000 BTU / hr (includes inverter, chassis must have minimum 160 amp alternator)
20 gpm water pump
Hydraulic tool package
Second operator station
Additional toolboxes
Debris body vibrator
Fold down pipe racks
1300 gallon stainless steel water tank
Sludge pump
For additional options, consult factory

Your Vactor representative is:

VECTOR
Subsidiary of Federal Signal Corporation

1621 South Illinois Street, Streator, Illinois, U.S.A. 61364
(815) 672-3171 Phone • (815) 672-2779 Fax
www.vactor.com

Some items shown may be optional.
Specifications subject to change without notice.
Vactor® and HXX® are registered trademarks of Vactor Manufacturing.
Effective 11/10 P/N 0072C Printed in U.S.A.
Produced at Vactor Manufacturing, whose quality management system is certified to ISO 9001:2000.

©2010 Vactor Manufacturing